



Composite Water Cartage/Spray Tanks



1300 139 971

Manufactured by Chemstore Group Pty Ltd



UNBEATABLE ADVANTAGES

ULTRA LIGHT

Easy to handle,
increased payload

UNIQUE DESIGN

Streamlined, low profile
design.

UNMATCHED DURABILITY

95°C heat distortion
temperature

UNRIVALLED CORROSION PROTECTION

No rust!!

ULTIMATE STRENGTH

Manufactured in
reinforced composite

UNSURPASSED DESIGN LIFE

20 year warranty.
No maintenance

UNPARALLELED STABILITY

Fully integrated baffle system



ULTRAVIOLET PROTECTION

UV stabilised material.

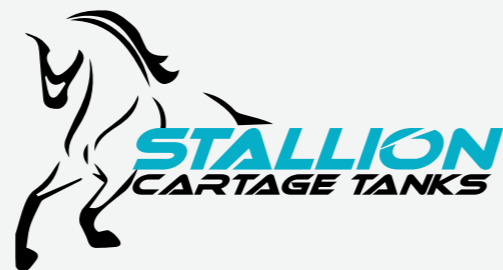

SPRAY CONFIGURATIONS

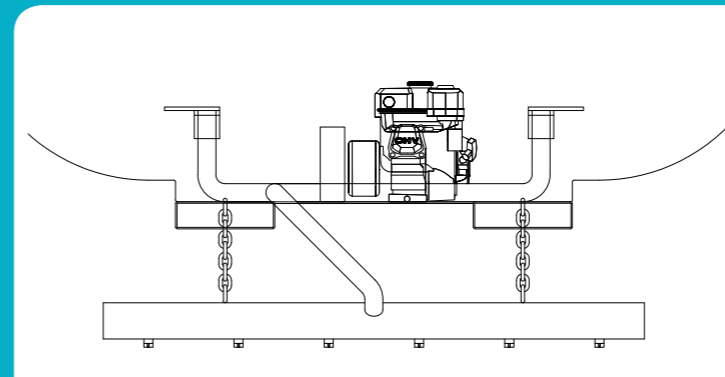

PREMIUM SPRAY UNIT

\$7429.00

- Honda GX160 electric start in roll cage
2" firefighting pump – maximum free
Delivery 490 lpm at 100 psi
- Variable pressure valve
- 2 X batter Sprays
- 1 X 32mm galvanised dribble bar with six fixed
angle spray nozzles on split eyelet connectors.
- All nozzles have ball valves.
- Camlock fittings on hoses and Batter spray nozzles.

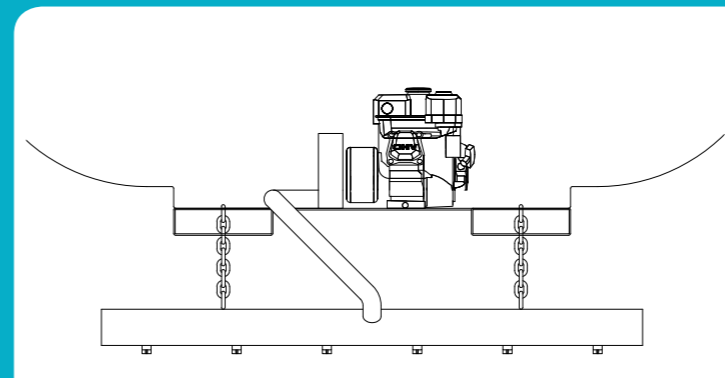

STANDARD SPRAY UNIT

\$6137.00

- Honda GX160 electric start in roll cage
2" firefighting pump – maximum free
Delivery 490 lpm at 100 psi
- Variable pressure valve
- 2 X batter Sprays
- All nozzles have ball valves.
- Camlock fittings on hoses and Batter spray nozzles.

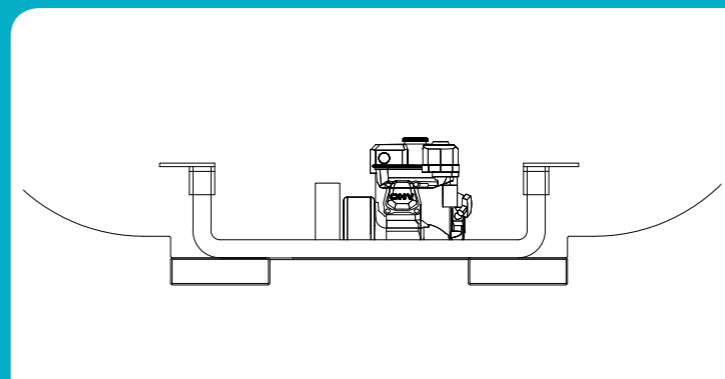

DUST SUPPRESSION UNIT

\$6443.00

- Honda GX160 electric start in roll cage
2" firefighting pump – maximum free.
Delivery 490 lpm at 100 psi
- Variable pressure valve
- 1 X 32mm galvanised dribble bar with six fixed angle spray
nozzles on split eyelet connectors.
- All nozzles have ball valves.
- Camlock fittings on hoses and Batter spray nozzles.

*Remote control options and higher pressure pumps are available.
Prices quoted exclude GST.



TANK SPECIFICATIONS

800 LITRE

\$1487.00 incl gst

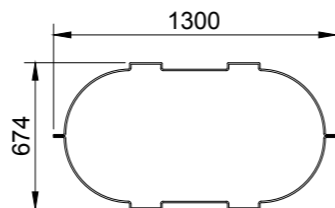
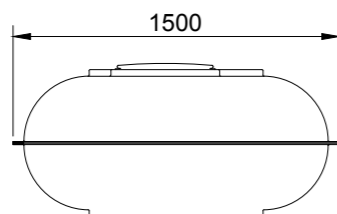

1500 LITRE

\$2124.00 incl gst

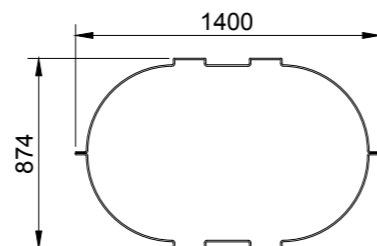
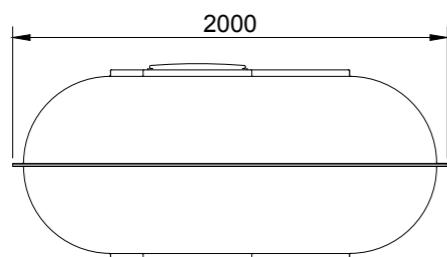

2500 LITRE

\$3229.00 incl gst

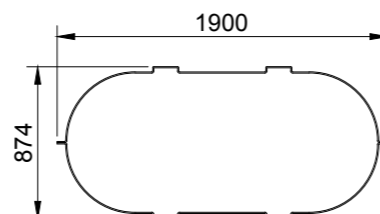
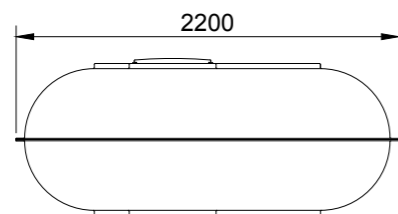

3500 LITRE

\$4727.00 incl gst

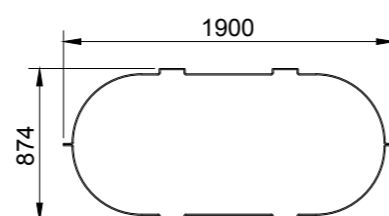
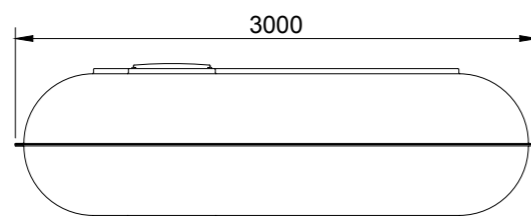

5500 LITRE

\$6835.00 incl gst

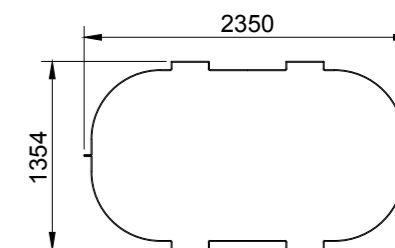
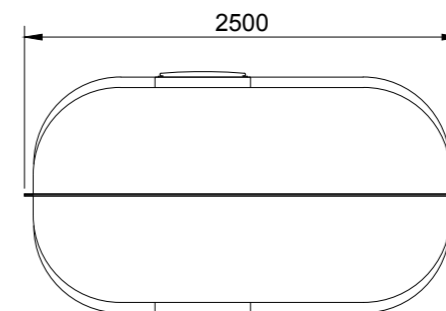

7500 LITRE

\$7950.00 incl gst

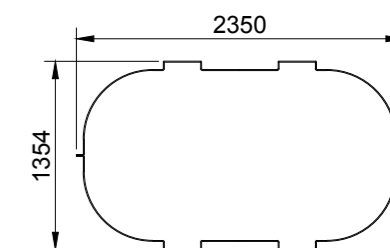
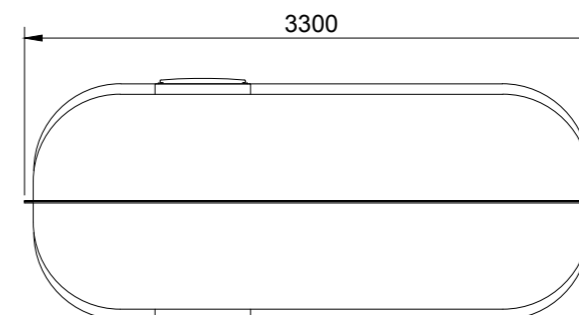

9500 LITRE

\$10835.00 incl gst

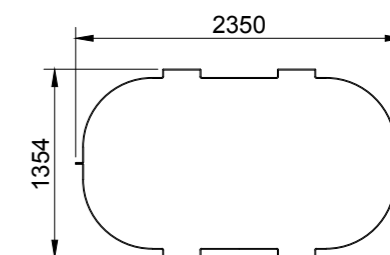
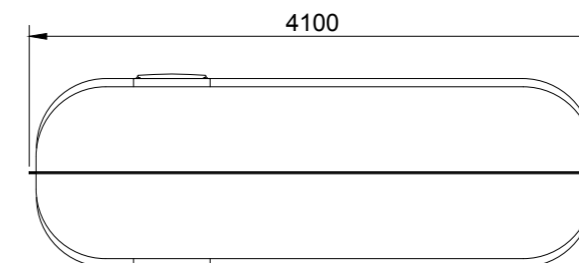

13500 LITRE

\$13897.00 incl gst

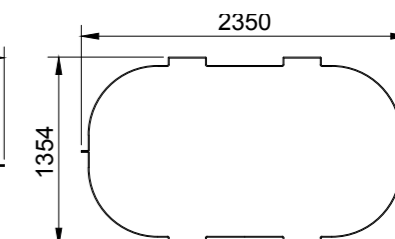
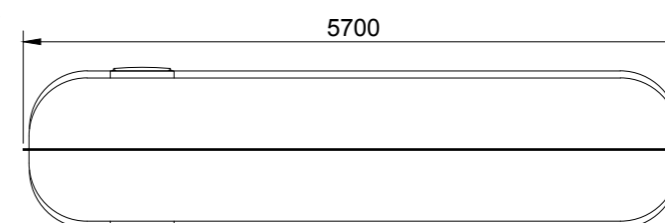

CALL US 1300 139 971

ADD A STEEL MOUNTING FRAME



FREIGHT GUIDE



Our service to you includes free freight to your local store in as many areas as possible. Our aim is to supply your order as quickly as we can & will advise delivery time frames upon receipt of your order.

There are areas we are unable to offer free freight. In these areas we offer a simple calculation to estimate freight costs, and we are happy to work with you to get the best freight prices.

Urgent deliveries may incur a freight charge and the above percentages do not include trailers. Please contact us to discuss.

	800 (L)	1500 (L)	2500 (L)	3500 (L)	5500 (L)	7500 (L)	9500 (L)	13500 (L)
Skid without Pump Base	\$908	\$1537	\$2157	\$2784	\$2984	\$3467	\$3667	\$4245
Skid with Pump Base	\$1108	\$1737	\$2357	\$2984	\$3184	\$3667	\$3867	\$4445



Manufactured by Chemstore Group Pty Ltd

19-21 Clarke St, Parkes NSW 2870
1300 139 971 | www.chemstoregroup.com.au