



**State of the Art Chemical &
Vacuum Transport Tanks**

Contents

Introduction	3
Advantages	4
Vacuum Tankers	5
Chemical Tankers	7
Water Cartage Systems	8
Configurations	9
Accessories	11



Introduction

Econoliner, as a division of Chemstore International Group, manufactures a range of GRP Chemical and Vacuum Transport systems. Built using the most sophisticated technology available, these units are made to last. Our tanks are a proven system with more than 35 years of history, and have on many occasions outlived their time under the most harsh and corrosive chemical environments. They are approved by the Environmental Protection Agency (EPA) for the road transport of dangerous goods.

The Econoliner range of transport tankers is available in many configurations and capacities from a 1000L Demountable to 25000L/13500LB B Double combination. All our systems are custom built with a large range of accessories available, including walkway and track options, valve and fitting accessories and pump fit outs. Our design team can also recommend resin systems, corrosion systems and complete design specifications.

Advantages

Our tankers have many advantages over other competitors such as:

- Transportation of dangerous goods chemicals that cannot be handled by stainless steel and aluminum. No more corrosion problems.
- Fuel saving and payload efficiencies due to the light weight of the tankers.
- Low maintenance costs.
- High Corrosion resistance meaning savings in operational and replacement costs and a longer lifespan.
- Vacuum and Pressure ratings up to 100Kpa and -100Kpa.
- Custom designs. Our design team will work with you to meet your specific requirements.
- Full fit outs ready for immediate work.

For these reasons FRP Road Tankers are the smart choice for use in the transport industry.

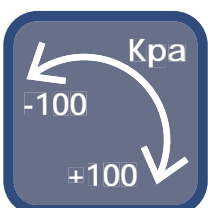

Vacuum Tankers

Econoliner have designed the ultimate vacuum tanker, one that will not rust, corrode or decay!

Our tankers, constructed in fibreglass reinforced plastic are the premium vacuum tanker in the market today. These tankers can be classed and registered as a dangerous goods unit for the collection of acid and industrial wastes etc.

Econoliner tankers are a proven system with more than 35 years of history, and have on many occasions outlived their time under

the most harsh and corrosive chemical environments.

Our innovative design team has now designed Australia's first composite tipping FRP vacuum tank complete with a hydraulic opening and locking rear hatch. Econoliner's experienced team can work with you to design and build a unit to your specific requirements.

The vacuum tanker can be supplied as just the tank designed to fit to your supplied framework/chassis, or as a complete fitted



Chemical Tankers

A Chemical tanker that has been around in service for over 35 years, and has been proved as a reliable, robust and dependable unit in the most aggressively corrosive conditions, is one you cannot go past.

Suitable for the transport of chemicals such as sodium hypochlorite, ferric chloride and sodium hydroxide, Econoliner chemical tankers are the solution for your needs.

Our professionally trained staff will recommend the most appropriate corrosion resistance barrier for the service environment. Our tankers can also be installed with a polyethylene liner for specific service conditions.

Econoliner tankers can be manufactured to many configurations and most importantly, custom fabricated to meet your designs.

Let our design and engineering team work with you to get exactly what you require.

out unit including many options available such as:

- Wireless remote controls which can operate Hydraulic systems, Work lights, Valves ect.
- Water tanks for cleaning and hydro excavation
- Hydraulic rear hatch
- Pressure cleaners
- Complete vacuum systems
- Hose trays
- Toolboxes
- Electronic depth gauges

- Air operated valves
- Stand Fast systems
- Walk way and ladder systems
- Work lights
- Hose reels
- Tipping units
- Mine specifications

Our design team can also recommend resin systems, corrosion systems and complete design specifications.

All Econoliner's vacuum tanks are designed to meet Australian standards for pressure vessels.





Water Cartage Systems

Econoliner includes a range of water transport and spray carts. These systems can be manufactured as demountable, fixed units, or truck or trailer mounted. These carts are lightweight making them ideal for the operator on the move. With a quick tie down/release system they are the most efficient of their kind.

Over the years these systems have worked to far exceed their expectations in the construction, road building, dust control and water industries. Speak to our professional team today to receive more technical information on the Econoliner Water Cartage range.

Configurations

Demountable

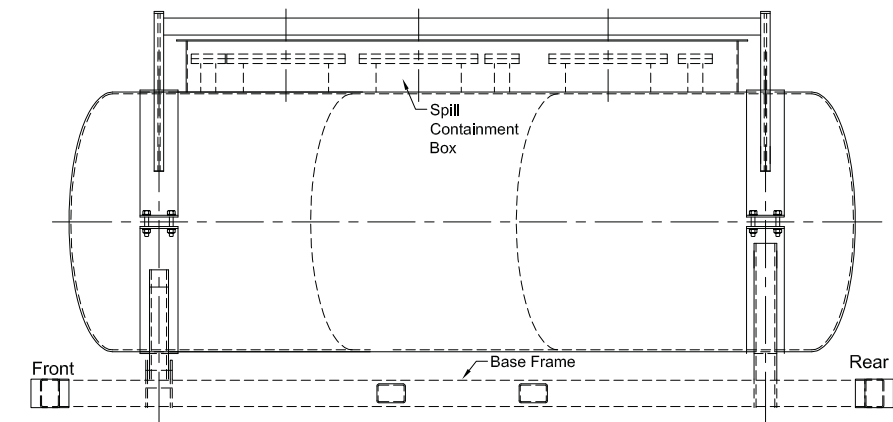

Rigid mounted

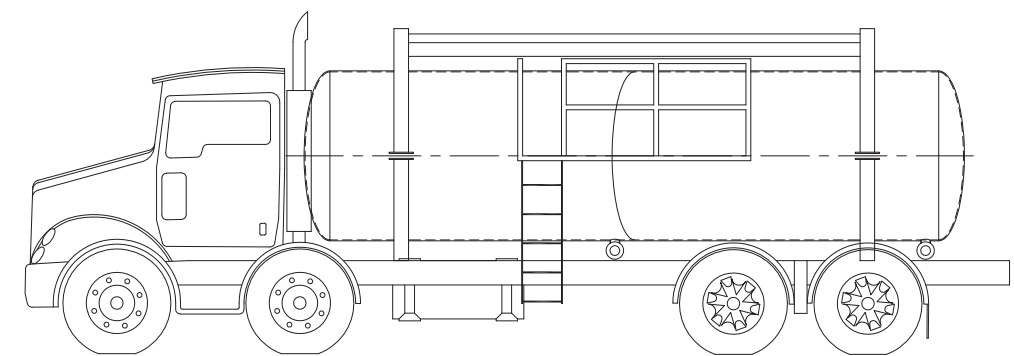

B double

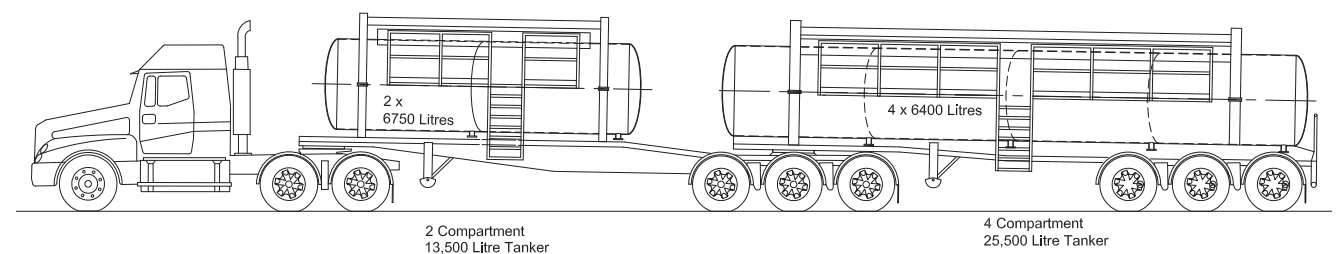

Configurations

Small tandem trailer mounted

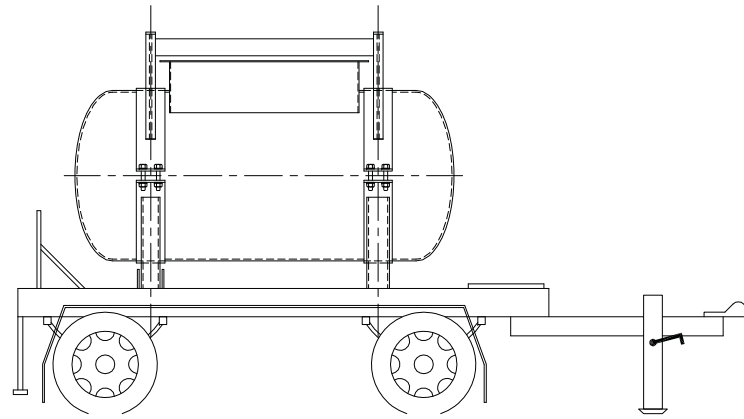

Dog trailer configuration

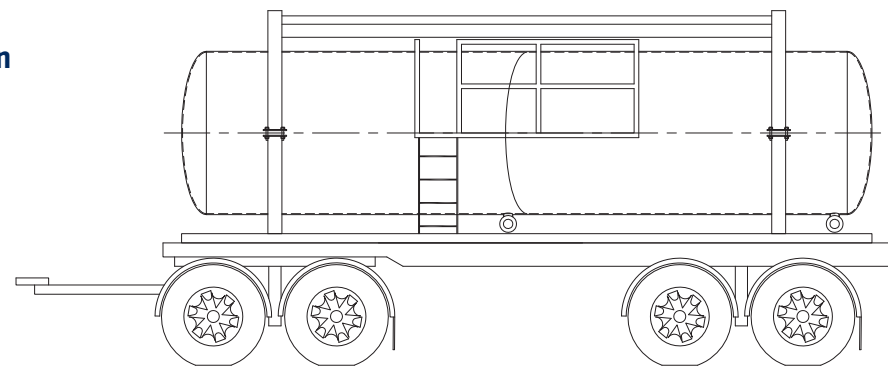

Tri axle semi trailer

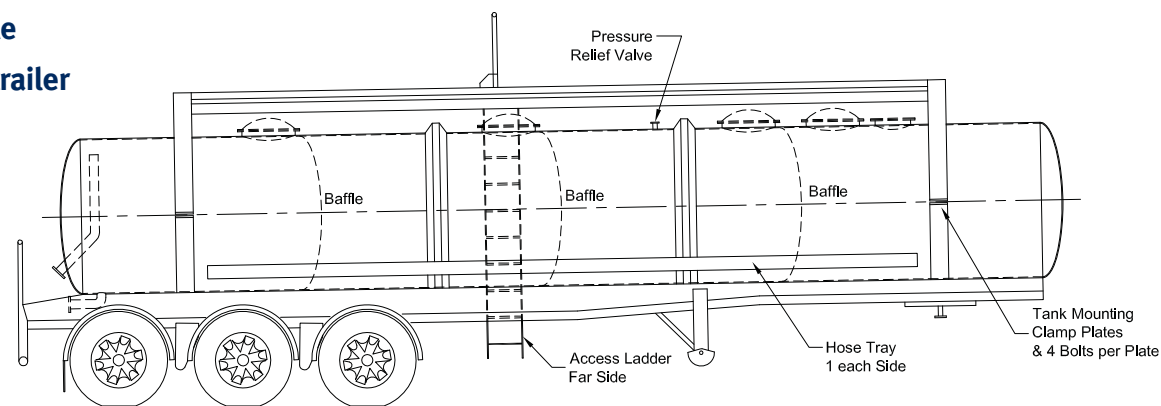

Accessories

Hose Reel



Tram Rail System



Pumps



Walkway & Ladder



Vacuum equipment accessories



Valves & fittings



Remote Control



Pressure Cleaner





A DIVISION OF CHEMSTORE INTERNATIONAL GROUP

19-21 Clarke Street | PO Box 1045 | Parkes NSW Australia 2870

Tel: +61 2 6862 4866 **Fax:** +61 2 6863 5766

Email: sales@econoliner.com.au **Web:** www.econoliner.com.au